

360° end-of-line inspection miho Allround



1 miho Allround | Functions

1.1 Overview functions

- 360° inspection of a fully equipped bottle after the labelling machine or after the sleeve
- Full inspection of up to 5 labels on one container
- Inspecting the cap for presence and correctness (via additional module, see 1.3)
- Vacuum control (via additional module, see 1.4)
- Inspecting the fill level (via additional module, see 1.5)
- Inspecting the expiry date imprint, directly on the container (via additional module, see 1.6)
- Network connection prepared

Closure (incl. cap insert)	
Presence	✓
Correctness (color/print)	✓
Position	✓
„Frothing“ (for swing top bottles)	✓
Vacuum	
Bending of the cap	✓
Fill level	
Underfilled	✓
Overfilled	✓



Labels	
Presence	✓
Correctness	✓
Position	✓
Intact	✓
Expiry date	✓
EAN-code	✓
Sealing label	✓
ACL	✓

- Mastering the increasing complexity through a comprehensive and intuitive operating software with connection to the network or the PDA system
- Allows for complete documentation to protect the consumer in terms of HACCP in IFS, ISO or Track & Trace
- The inspection of a fully equipped bottle separately behind the labeller/sleever has many advantages over the installation of cameras in the unit:
 - More hygienic
 - More robust, as no sensitive cameras are installed in the unit
 - Flexible with subsequent new container types, label types and equipment variants (format change)

1.2 Labels



1 miho Allround | Functions

1.3 Additional module cap inspection



1.4 Additional module vacuum



1.5 Additional module fill level inspection



1.6 Additional expiry date detection module



2 miho Allround | Technology

2 Technology

- **Four side cameras** use a **mirror cabinet** to create a **processed image** of the **entire container** with a **360° all-round view**
- **Top camera** to inspect the **cap** (optional)
- Connection of a miho **fill level inspection unit**
- **The latest computer technology.**
New platform miho **VIDIOS®**: was especially developed by miho for inspection tasks and enables innovative image-processing
- Up to **60 000 container/hour**
- **Remote maintenance**
- **Production data acquisition** (Weihenstephan Standard)



- **Touchscreen:**
Intuitive user interface with context help
- **Integration of miho reject systems:**
 - Linear reject system miho Leonardo M for the safe standing rejection of containers
 - High Speed Pusher miho HSP
 - Multi-reject system miho HSPM
 - Eccentric reject system miho ESF 2

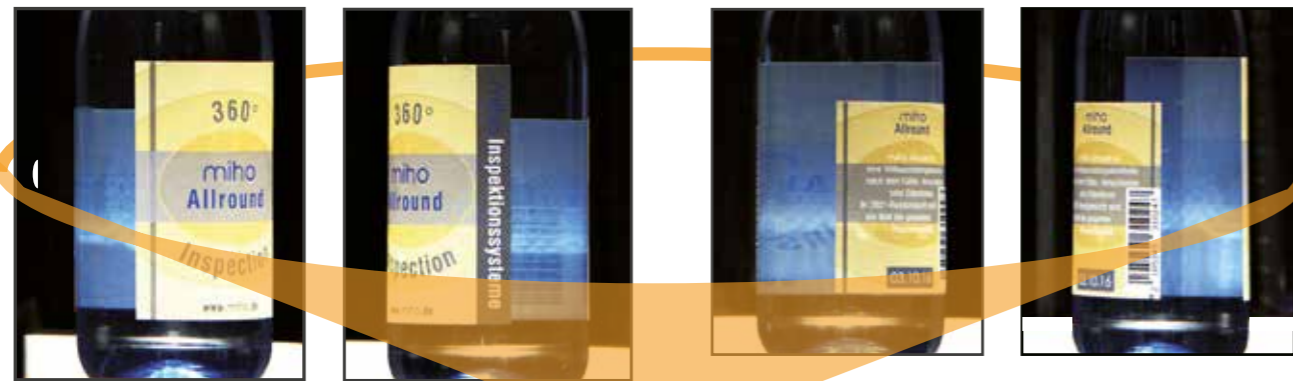

The four individual images of the side cameras (top) and the completely processed and rectified overall image of the bottle (bottom)

3 Advantages

- **Simplest variant management:**
Hundreds of equipment variants are easy and quick to handle.
For easy management there are three levels available:
1: Container type (factory configured)
2: Product
3: Variants
- **Graphically guided self-commissioning new equipment variants,** based on the processed image of a reference container. Inspection features are created by copying an appropriate predecessor and are intuitively adjusted step by step
- Inspection of the presence and correctness of the **barcode** and **expiry date** (laser and inkjet)
- Quick introduction through **Quick Start Guide for self-commissioning**
- **Hygienic design**
- **Separate inspection system downstream of the labelling machine:**
 - Therefore no contamination and no misalignment of the remote cameras in the labelling machine for conversion/change of type
 - Hygiene in the labelling machine
 - No restrictions for space requirement for change of type
 - Future-proof even with new bottle types/equipment variants
- **Easy retrofitting in existing systems** with small space requirement as a complete and integrated solution
- **Fill level inspection:** can be combined with optical, HF, IR or X-ray fill level inspection

miho Allround | Advantages 3

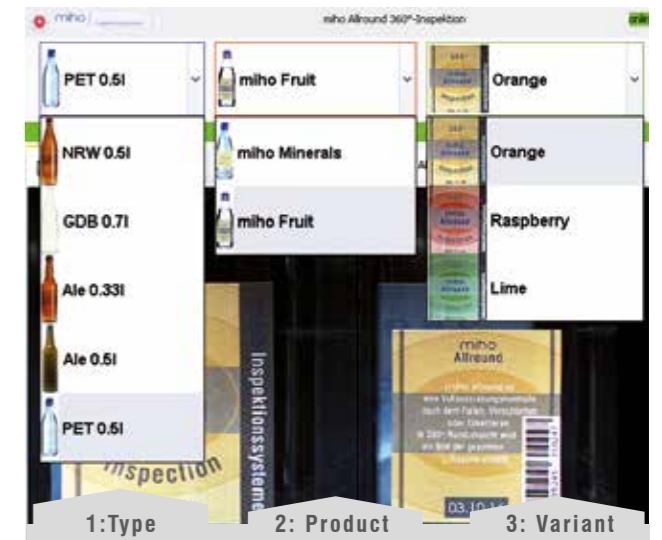

Easy adjustment of new variants



Easy teach-in of new reference labels



Detection of the „crease“ fault on the basis of the miho image-processing platform miho VIDIOS®

3 miho Allround | Reject systems

miho rejection - three systems for different requirements:

- The appropriate reject system, depending on the function and requirement
- All reject systems including reject monitoring
- Central control system through the 360° end-of-line miho Allround

3.1 Reject system miho HSP

Function

- To reject the faulty bottle via a pneumatic pusher
- Including reject monitoring in the inspector

3.2 Multi-reject system miho HSPM

Function

- Universal use in glass and plastic bottles, as well as in cans or carton packaging, empty or filled
- Up to 60 000 containers per hour
- Different container shapes and weights are compensated thanks to the servo-control of the linear drive and have no influence on the motion sequence of the reject block
- The reject process is individually configured for different container types and optimized for the respective container type

Technology

- The reject block of the miho HSPM is driven by an optimized high speed linear servomotor
- Parameterization and operation integrated in upstream inspection unit
- Low maintenance and durable
- No compressed air supply necessary
- Including reject monitoring in the inspector



miho HSPM: multiple rejection (red arrows), depending on the type of bottle defect

3.3 Segment reject system miho Leonardo M

Function

- Secure standing rejection of bottles, cans and carton packaging, even of difficult bottles in terms of shape and centre of gravity
- Suitable for sorting tasks

Technology

- Magneto-mechanical reject system: containers to be rejected are transferred to a parallel conveyor by slide segments which run synchronously and parallel to the conveyor
- Gearless drive via toothed belt, thus less mass movement and low-wear
- Torque monitoring of the servomotor through slip clutch
- Including reject monitoring in the inspector



miho Leonardo M, slide segments in action

Reject principle:
The mechanical core piece of the **Leonardo M** is the approximately **100 reject slides (1)**, each one being connected to its own private **guide element (2)**. They are all permanently driven parallel to the reject conveyor (**green line**) by a rotating **chain** and synchronously with the belt speed. If a bottle is to be rejected, the **central switching unit (3)** electromagnetically moves two or three of the guide elements in a mathematically calculated **curve (red line)** vertically to the running direction of the conveyor. Thus, by activating the reject slides in this way, the bottle to be rejected is pushed **gently and securely standing** onto the parallel reject conveyor (left reject conveyor, not pictured).

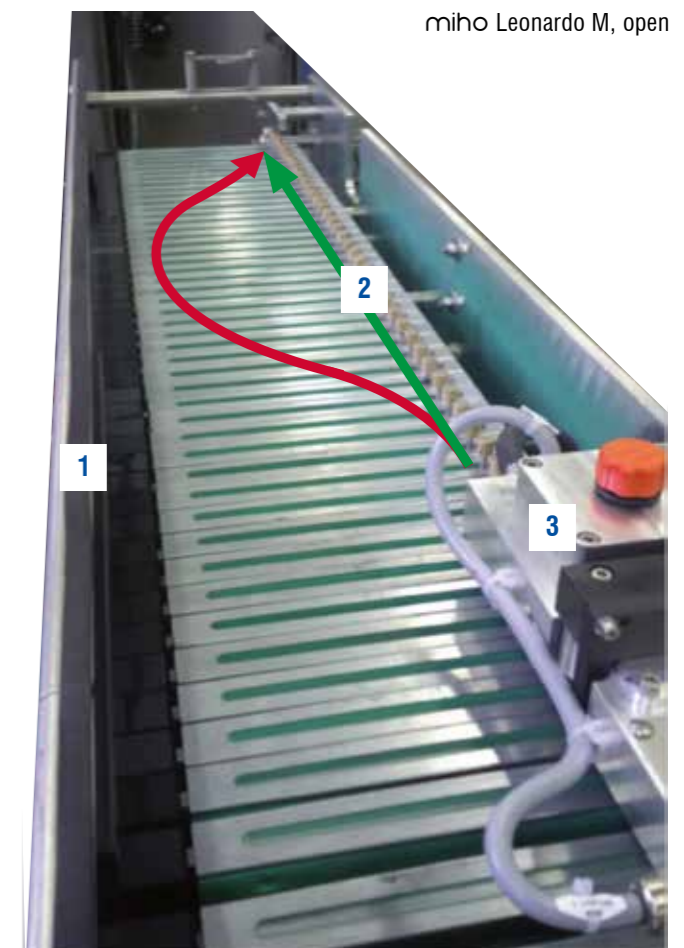

miho Leonardo M, open

4 miho Allround | Network integration & Production data acquisition

4.1 Production data acquisition system (PDAS) miho AWeS

Function

- Visualization and logging of:
 - Counters
 - Operation status
 - Warning and error messages
 - User registrations
- To monitor single or multiple miho machines, such as the empty bottle inspector miho David 2, the inspection of a fully equipped bottle by the miho Allround, the fill level inspection miho Newton Optics 2, ...
- Export of data in pdf or xls format for further processing
- **Buffering data on the inspection machine in the case of a network failure over 7 production days - No data is lost.**

Production Data		Machine Data		Logging	
Overview					
Total bottles	67986	Underfilled bottle	4711	(0.70 %)	*
Good bottles	638135	Overfilled bottle	207	(0.13 %)	*
Bad bottles	37367	Closure fault	6882	(1.02 %)	*
therefrom into container	8474	Date coding fault	1240	(0.80 %)	*
therefrom to return conveyor	0	Labeling fault	2834	(0.52 %)	*
therefrom to undefined reject	30893	Vacuum fault	82	(0.01 %)	*
Manually removed bottles	404	Other faults	7	(0.00 %)	*
		Broken bottle	0	(0.00 %)	*
		Long bottle	13	(0.00 %)	*
Machine speed (bottles/minute)					
Machine design speed	1200.00				
Current machine speed (Average)	261.69				
Current machine speed (Peak)	1171.87				
Printer- and failure messages					
Number of printers	35				
Number of failures	86				
<input type="button" value="Show Printer-Report"/> <input type="button" value="Show Failure-Report"/>					

Image cut-out miho AWeS: Production data statistics

Technology

- Polling the production data in accordance with the **Weihenstephan standard**, allowing easy integration into a PDAS
- Either installation into the network on a virtual machine or on a separate PDAS computer from miho

miho AWeS as the central PDAS

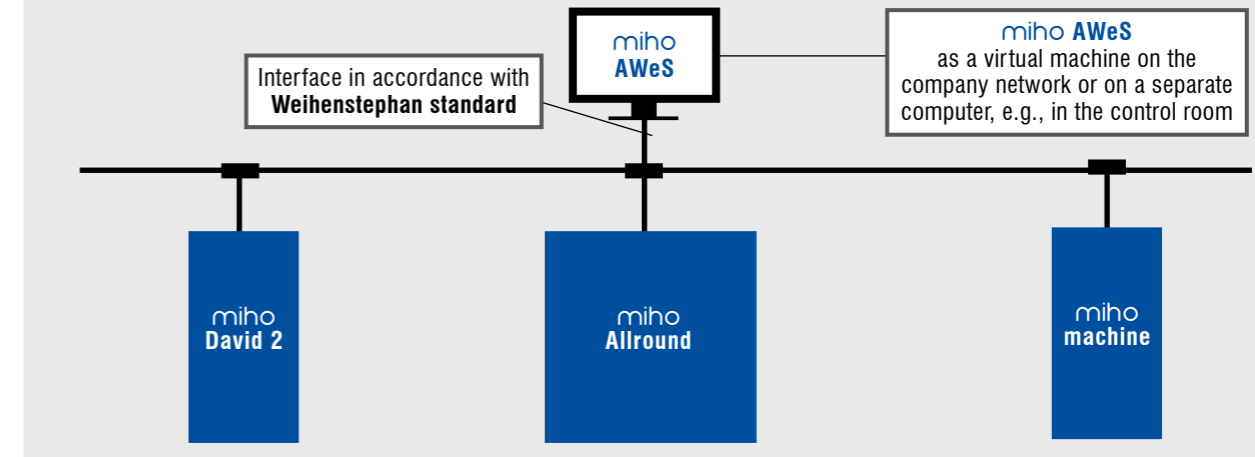

Integration of miho machines into an existing PDAS

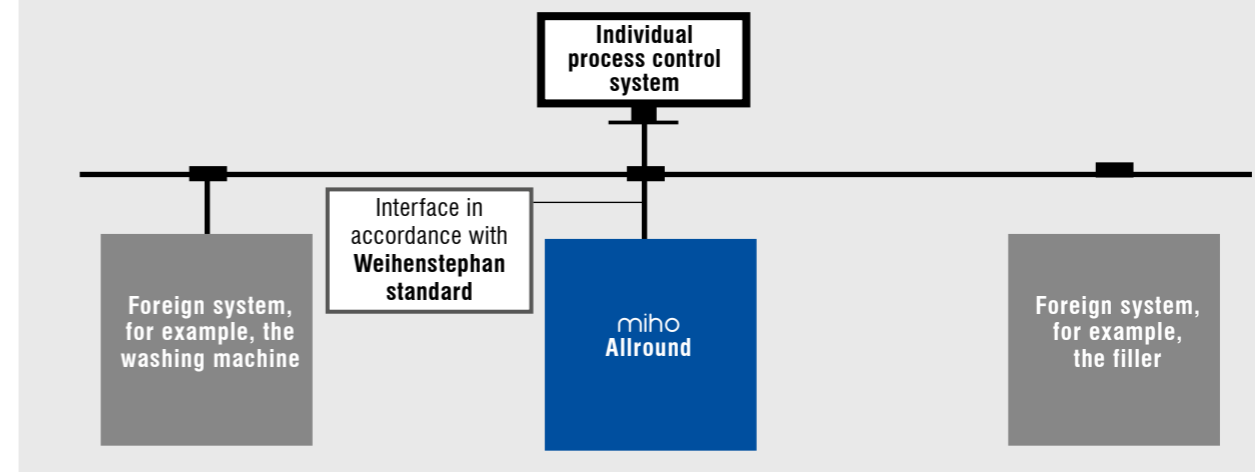

4.2 miho remote maintenance

Funkcion

Software package for remote visualization of the operating status, the parameters and images on an authorized computer of a miho service engineer: monitoring of counters and disruptions, checking and operating the inspection systems, new input and optimization of inspection parameters, accurate and quick analysis of faults.

Technology

- Internet access with data transfer of at least DSL standard
- **OpenVPN**, a globally recognized tool for establishing a **virtual privat network** via an encrypted TLS connection, or alternatively with TeamViewer (licence supplied by the customer)

4.3 Connection to a process control system

External product switching through a higher-level operational **production data acquisition system** is possible. The product may for e.g., be read with the help of a barcode scanner. Then a signal is sent to the 360° fully equipped bottle inspection unit miho Allround to switch products. This signal is transmitted by the higher-level system as per **Weihenstephan Standard** and can be processed accordingly by the fully equipped bottle inspection unit miho Allround and a product switchover takes place.

Russian Crypto Code Law for the prevention of tax evasion with alcohol and the solution

At the end of 2018, the Russian Federal Law NO 488-FZ was passed relating to a serialisation with crypto protection for complete traceability in the case of alcoholic drinks such as alcopops, wine and spirits (beer is still currently excluded) via tax stamp (ECC200 code with 40x40 modules or PDF417).

With this traceability, any tax fraud through fake alcoholic drinks should be prevented. The filled container is laterally marked after filling and capping with the tax stamp and a 2D Data Matrix code on the top of the container. The fully equipped bottle inspection unit miho Allround reads this individually on the adhesive information on the container, provides them with a time stamp, brings them together, creates an XML file and passes them to a designated parent database. The container only passes the Allround if both codes have been clearly read.



5 miho Allround | miho Conveyance container transport

From a single source:

360° end-of-line inspection
miho Allround



Conveyor control
miho Pascal 2



Container transport
miho Conveyance

5 Container transport system miho Conveyance

- Conveyor construction made out of stainless steel
- Depending on the project conveyor chains made out of stainless steel or plastic are possible (Rexnord)
- Curved conveyors with magnetic chain guides
- Bottle railings are made out full profile stainless steel, with plastic bottle guides depending on the requirements of the project
- Railing holders made of stainless steel
- Piping for conveyor lubrication made of stainless steel pipes, for the connection to the existing lubrication system
- Stainless steel wire-basket cable trays, open

- Modular container transport system for modern filling and sorting systems
- Single and multi-lane conveyors, pressureless combiners, buffer systems and reject tables
- High quality reject tables from miho are a requirement for secure standing rejection
- Hygiene-friendly design details
- Pre-assembled in the factory, thus short installation and commissioning times
- miho Conveyance and miho Pascal 2 form a combined basis for smooth production and high plant efficiency



Reject table, with belt lubrication, height-adjustable foot receptacle and optional drip tray



Curve with optional drip tray and height-adjustable foot



Two-sided rail adjustment



Optional conveyor belt cover



Mechanical pre-assembly in the factory at miho



miho Conveyance, individual special solution for collecting lying bottles in hard to reach places

6 miho Allround | Modular product system

6 miho Modular product system for the complete inspection between the filler and packer

Machine / module	Inspection task / function
miho Allround / basic machine	Labels, expiry date, barcode, swing top
miho Allround / top camera	Cap inspection
miho Allround / vacuum	Vacuum control (juice - wide neck bottles / glass)
miho Allround / expiry date detection	Expiry date detection directly on the container
miho Allround / AWeS	AWeS and remote maintenance
miho Newton Optics 2	Fill level inspection (foaming liquids), cap (slanting)
miho Newton HF 2	Fill level inspection (standard)
miho Newton X2	Fill level inspection (fill level covered by label/canned)
miho Newton IR 2	Fill level inspection (liquids with pulp)
miho Feeler	Sealing (PET)
miho UIP	Ultrasound foaming for sealing inspection (glass and PET)
miho MX	Filling pipe detection
miho reject systems	HSP, HSPM, ESF 2, Leonardo M

Installation example 2: Reference layout of fruit juice filling, glass RG bottles 0.2 l - 1.0 l, 15 000 bottles per hour:

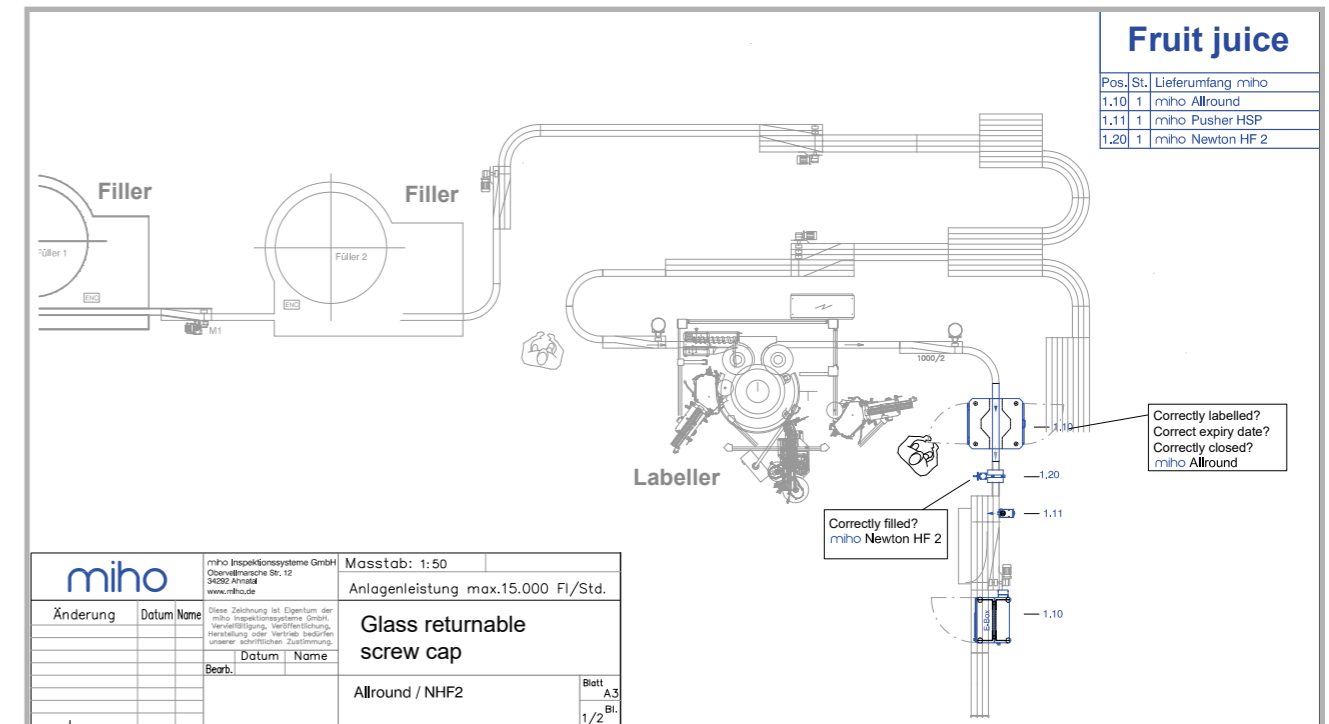

Installation example 1: Reference layout for beer filling, glass RG bottles 0.33 l - 0.5 l, 36 000 bottles per hour:

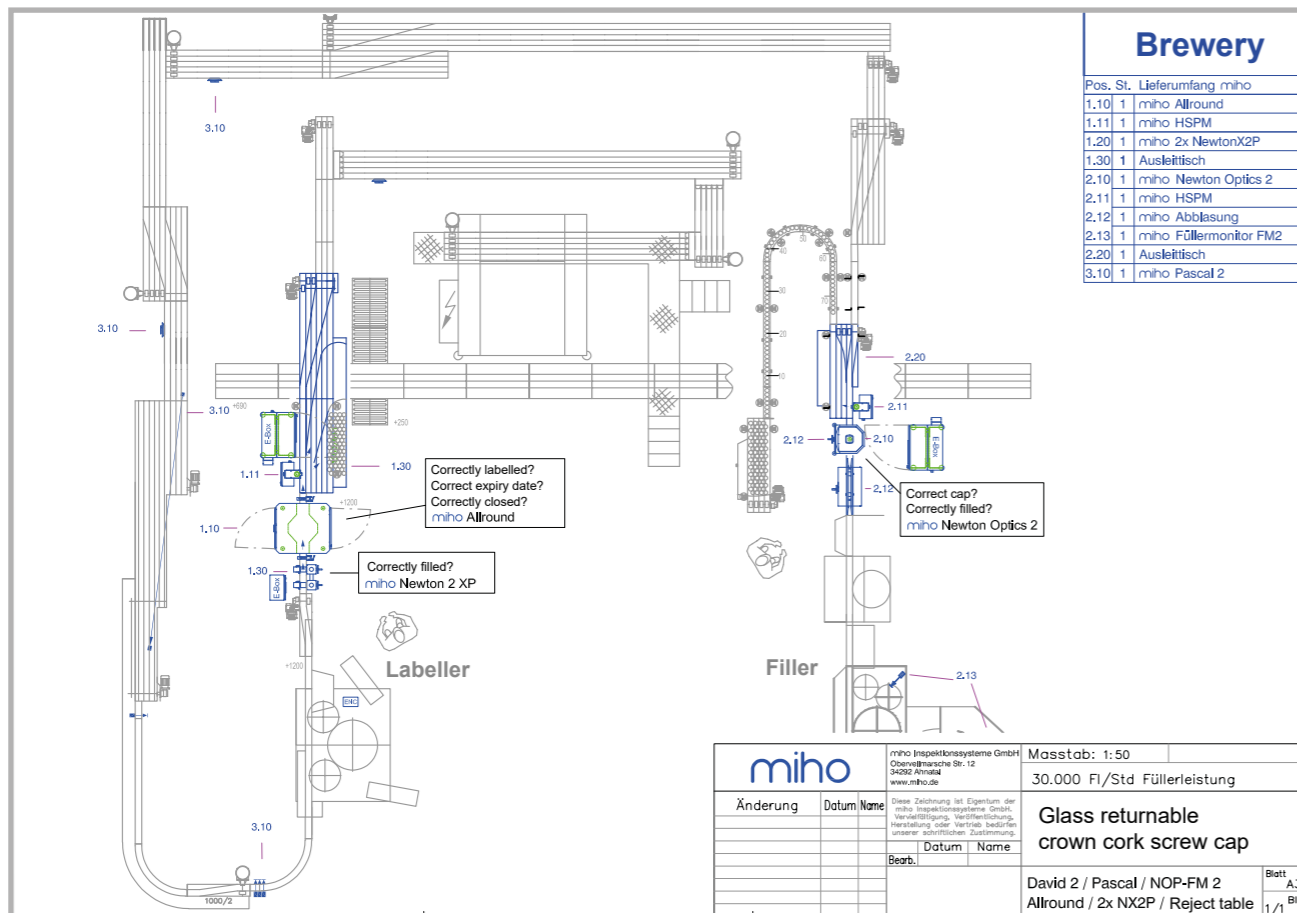

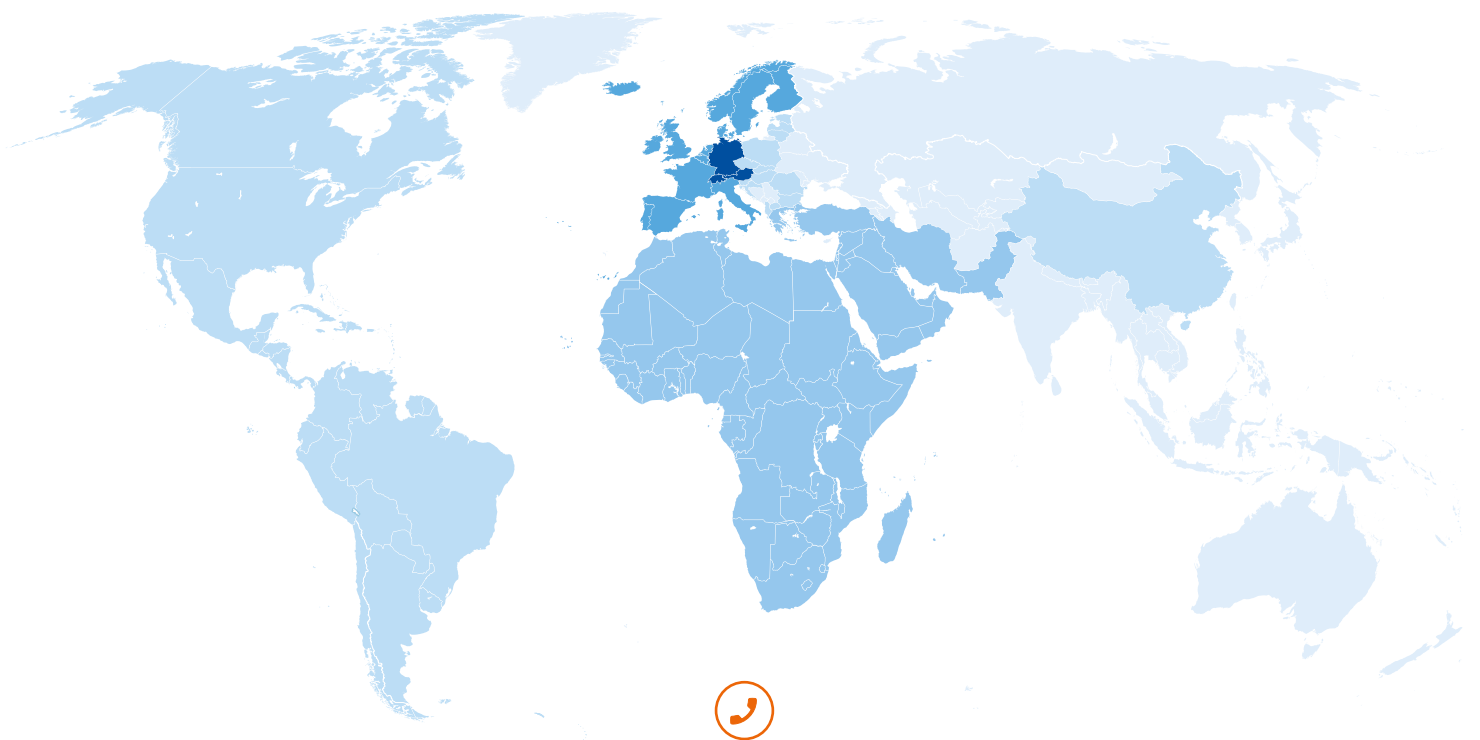

24/7 Service-Hotline

Service is everything!

If you have any technical questions about your miho systems, you can contact us at any time via our 24/7 hotline. You will receive competent advice on the phone from one of our service engineers. The call is subject to a charge.

Hotline number: +49 5609 8382-50 **Customer service:** service@miho.de

miho Inspektionssysteme

miho Inspektionssysteme GmbH · Obervellmarsche Str. 12 · 34292 Ahnatal · Germany
+49 5609 8382-0 · info@miho.de · www.miho.de